

350 01 226930C

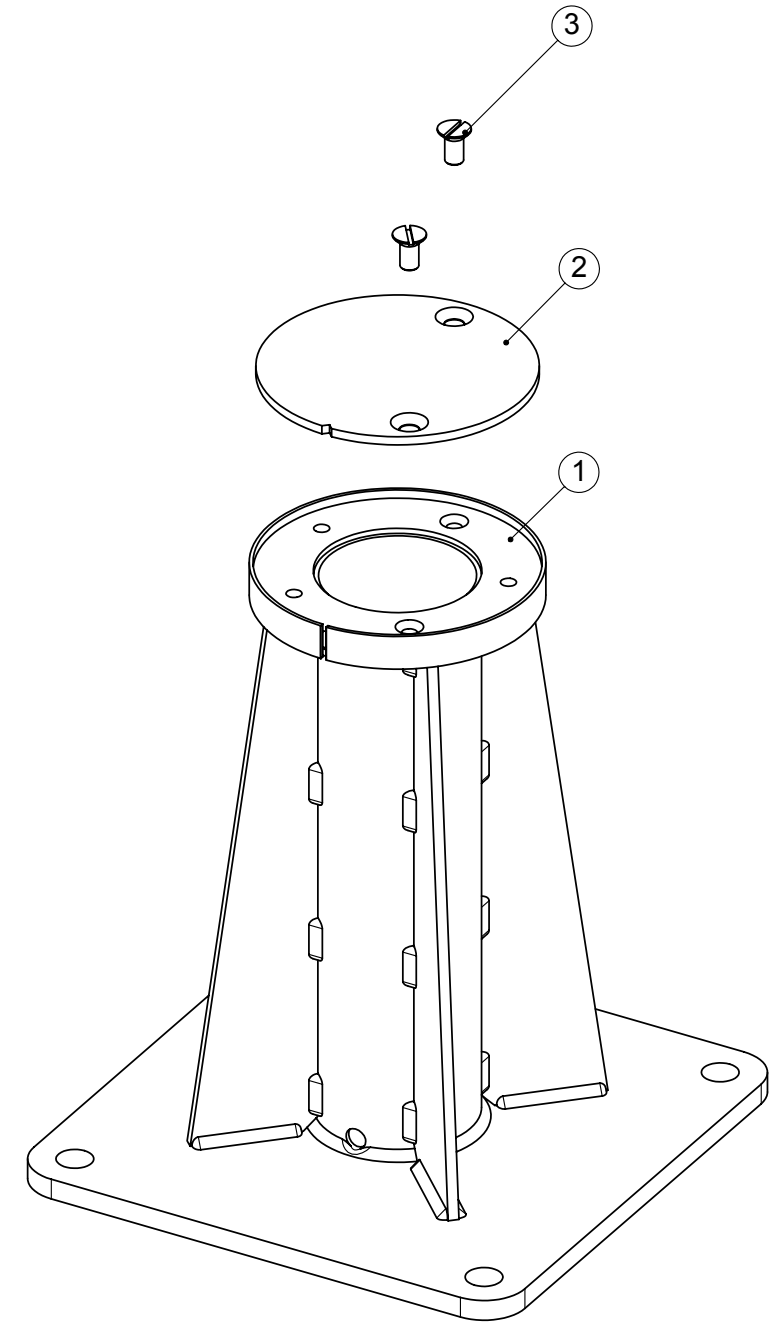
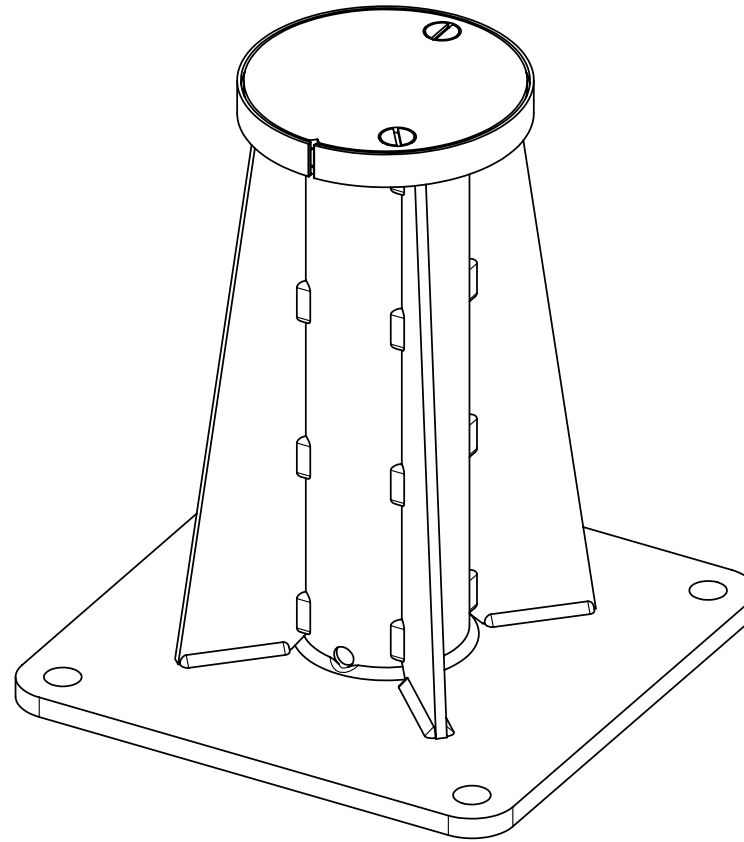
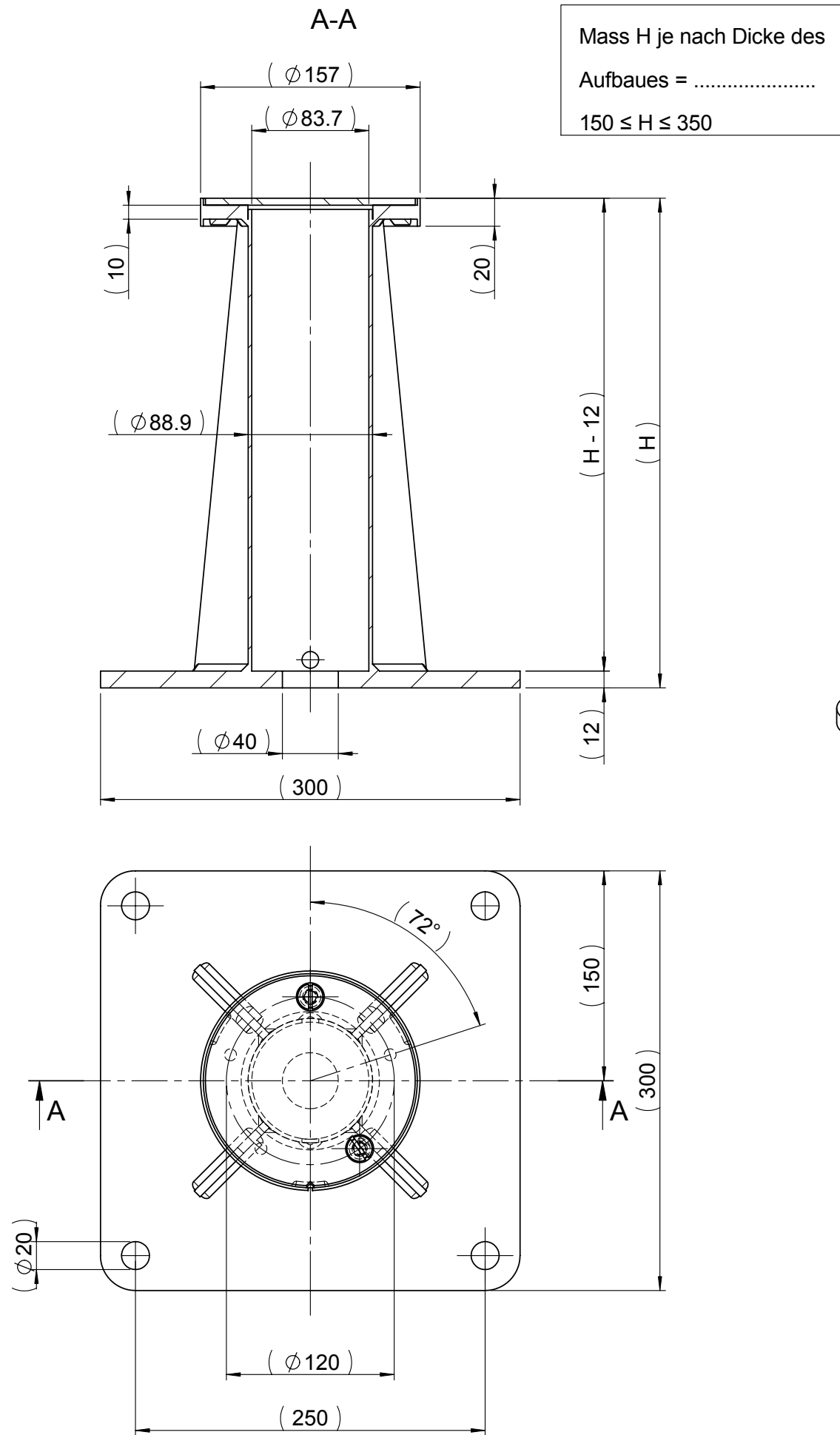

Gewicht ~14.5kg

2	Senk-Schr.m.Schlitz	M10/20	3	A2	370 03 776800	BN654, DIN963A
1	Deckel M4	Warzenbl. Ø150x3/5	2	AW-5754	251 02 746800	A Quintett
1	Montageplatte M4 spezial		1	St.	251 03 746930	D
Gegenstand			Pos. Werkstoff		Modell	Bemerkungen

Aenderungen:

Ersetzt durch:
 A3 Ersatz fuer:

Montageplatte M4 spezial
 für Aufbauhöhe 150-350mm

Masstab 22.09.2006 G/TR
 1:4 14.05.2007 G/EK

SolidWorks

1685 BOV



CH-8500 Frauenfeld

350 01 226930C